

Type SR Precision Current Sense Resistors



Non-inductive Design - Compact Footprint Minimizes Circuit Board Space Kelvin Terminals (Four Wire) - Resistance Values 0.008Ω to 1.00Ω

Type SR Current Sense Resistors utilize Caddock's Micronox® resistance films to achieve a low cost resistor with Non-inductive Performance. This compact construction makes this sense resistor ideal for many current monitoring or control applications.

The special performance features of these Type SR Current Sense Resistors include:

- Available in Standard Resistances down to 8 milliohm
- Non-Inductive Design
- Terminals are constructed for Kelvin connections to the circuit board
- Compact footprint

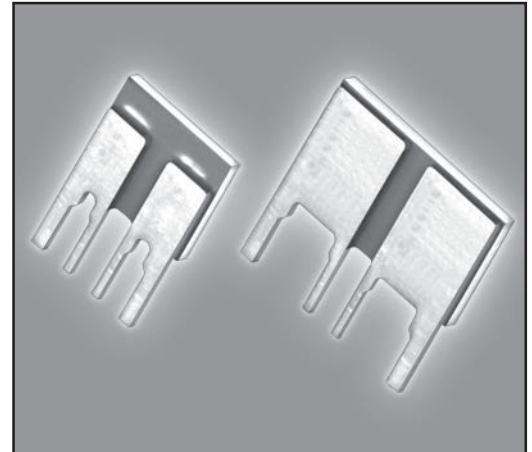

Model No.	Power Rating at 70°C *	Voltage Rating	Terminal Material
SR10	1.0 Watt	Power Limited	Solderable
SR20	2.0 Watt	Power Limited	Solderable

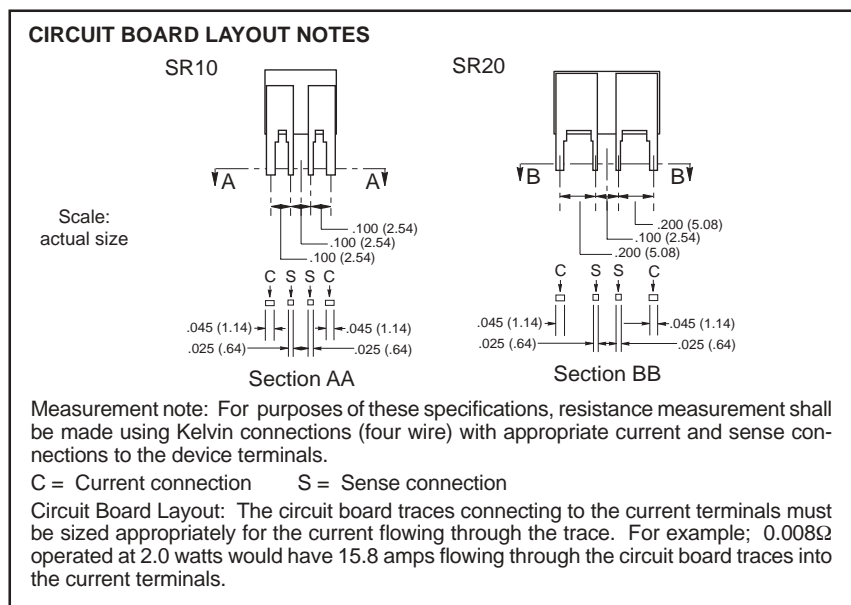
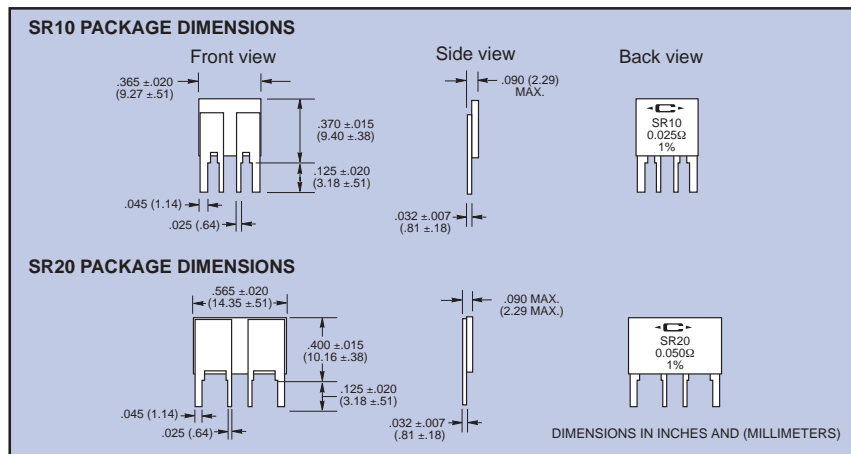

Standard Resistance Values:

0.008 Ω	0.030 Ω	0.10 Ω	0.75 Ω
0.010 Ω	0.033 Ω	0.20 Ω	1.00 Ω
0.015 Ω	0.040 Ω	0.25 Ω	
0.020 Ω	0.050 Ω	0.40 Ω	
0.025 Ω	0.075 Ω	0.50 Ω	

Custom resistance values can be manufactured for high quantity applications. Please contact Caddock Applications Engineering.

Specifications:

Resistance Tolerance: ±1.0%

Temperature Coefficient: TC referenced to 25°C, ΔR taken at -15°C and +105°C.

0.081 to 1.00 ohm	-50 to +100 ppm/°C
0.025 to 0.080 ohm	0 to +150 ppm/°C
0.008 to 0.024 ohm	0 to +200 ppm/°C

Load Life: 1000 hours at rated power at +70°C ΔR 0.2% max.

Thermal Shock: Mil-Std-202, Method 107, Cond. A, ΔR 0.2% max.

Moisture Resistance: Mil-Std-202, Method 106, ΔR 0.2% max.

Encapsulation: Polymer over resistance element.

Power Derating Curve:

* Power rating:

The power rating should be limited as shown by the derating curve based upon the maximum ambient temperature. The derating curve is based on still air with natural convection around the resistor.

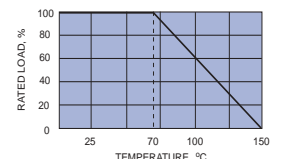

Ordering Information:

Model Number: **SR10 - 0.050 - 1%** Tolerance
Resistor Value:

Applications Engineering
17271 North Umpqua Hwy.
Roseburg, Oregon 97470-9422
Phone: (541) 496-0700
Fax: (541) 496-0408

CADDOCK ELECTRONICS, INC.

e-mail: caddock@caddock.com • web: www.caddock.com

Sales and Corporate Office
1717 Chicago Avenue
Riverside, California 92507-2364
Phone: (909) 788-1700
Fax: (909) 369-1151