

RS-422/RS-485 Pinouts

RS-422/RS-485 interface with RJ-45 Jack connector or Terminal Block Connector is depicted as follows.

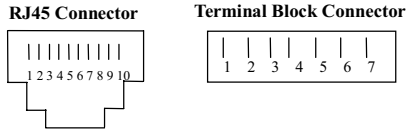

RS-422

A52/A53 RJ45 Jack Connector Pinouts	Signals
1	TxD -(A)
2	RTS -(A)
3	RTS +(B)
4/7	SG
5	TxD +(B)
6	RxD +(B)
8	CTS +(B)
9	CTS -(A)
10	RxD -(A)

A52/A53 Terminal Block Connector Pinouts	Signals
1	TxD +(B)
2	TxD -(A)
3	RxD +(B)
4	RxD -(A)
5	SG
6	Power GND
7	VCCA (9V)

Note : Pin 6 and Pin 7 of Terminal Block are for Power GND and Power Input, which is an alternate option for power adapter. Be careful that DO NOT confuse RS-422/RS-485 GND with Power GND.
SG: Signal Ground

RS-485

A52/A53 RJ45 Jack Connector Pinouts	Signals
1	Data-(A)
4	SG
5	Data+(B)
7	SG

A52/A53 Terminal Block Connector Pinouts	Signals
1	Data+(B)
2	Data-(A)
5	SG
6	Power GND
7	VCCA 9V

Note : Pin 6 and Pin 7 of Terminal Block are for Power GND and Power Input, which is an alternate option for power adapter. Be careful that DO NOT confuse RS-422/RS-485 GND with Power GND.
SG: Signal Ground

Transio A52/53

Smart RS-232 to RS-422/485 Bi-directional Converter

Overview

The A52/53 is a smart RS-232 to RS-422/485 bi-directional converter. It allows one RS-232 port to be converted to and from RS-422 or RS-485 port, which can thus control up to 32 devices within 1.2 km in a multidrop environment.

To ease the 2-wire RS-485 half-duplex control, an fully Automatic Data Direction Control (ADDC) intelligence with no baud rate switch setting design are built in each A52/53, simplifying RS-485 software programming. Hence, the applications can easily manage the data transmitting and receiving of the half-duplex RS-485 port without extra code. In addition, unlike the manual speed setting with switches that most other products provide, much developing and maintenance hassle are saved.

To meet the demand of high reliability in harsh industrial environment, all RS-422/485 signals provide TVS protection, ESD up to 25 KV. A53 additionally provides 2KV optical isolation protection for all signals at RS-422/485 end.

Features and Specifications

- Serial interface: RS-232, RS-422/485

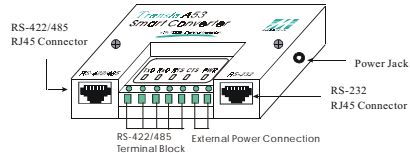

- Connector type: RS-232-RJ45, RS-422/485-RJ45 or Terminal Block
- High speed, baud rate up to 921.6Kbps, no switch setting needed
- Signals: RS-232-TxD, RxD, RTS, CTS, DTR, DSR, DCD, GND
RS-422-TxD+(B)/-(A), RxD+(B)/-(A),

- RTS+(B)/-(A), CTS+(B)/-(A), GND
RS-485-Data+(B)/-(A), GND
- Support fully Automatic Data Direction Control (ADDC) with no baud rate switch setting for RS-485
- RS-485 data control modes: auto (ADDC) or by RTS
- RS-422 support CTS, RTS signals for hardware flow control
- LED indicators for power and 4 signal states (TxD, RxD, RTS, CTS)
- All RS-422/485 signals provide TVS protection. (ESD 8 KV, EFT 2KV)
- All RS-422/485 signals support up to 2KV (DC) optical isolation protection (A53 only)
- Provide overloading protection when there are 2 signals shorted together at RS-422/485 end
- Built-in 120 ohm termination resistors for RS-422/RS-485 (selectable with jumper by RS-485 mode)
- Support up to 32 units connected together in RS-485 multidrop operation
- CE approval
- 9V 1.5A UL/ TUV 110V/230V power adapter can support up to 4 converters
- An external power adapter is required, the input voltage for converter ranging from DC +9V to +30V.
- Operating temperature: 0~55C
- Dimension: 90mm x 60mm x 21mm
- Mounting Kit: Plastic Plates and screws for mounting A52/53 on the wall or any surface.
- Power consumption: A52-157mA max. (+9V), A53-270mA max. (+9V)

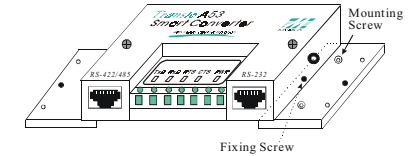

Applications

- Multipoint data acquisition
- Factory automation
- Remote serial device control
- Building security automation
- Critical industrial control



Installation Switch and jumper settings

Take off the two screws on top of the converter and open the cover up if you need to change the operation mode via sliding the switches.

DIP switches in the A52/53 converters set the operation mode (RS-422 or RS-485) and the control mode (By RTS or ADDC) for RS-485 mode.

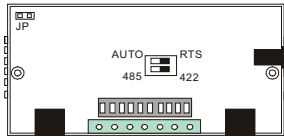

Inside look of A52/53

SW1	
RS-422 mode	Off
RS-485 mode	On*

SW2	
By RTS	Off
Auto Data Direction Control (ADDC)	On*

(*: Default settings)

In RS-422 mode, the RxD always put in a 120 Ohms terminating resistor.

In RS-485 mode, the 120 Ohms terminating resistor is put in by a jumper setting.

One Jumper to adjust termination resistor at RS-485 mode. When shorted, the resistor is enable.

Basic Communication Wiring

Before placing a converter in an existing network, the converter should be properly configured. The two following diagrams show typical layouts for both converters.

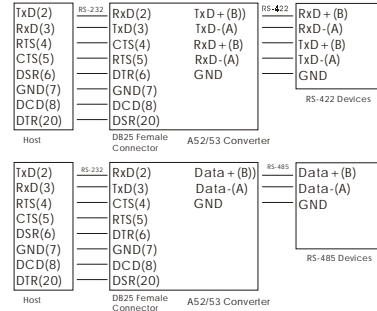
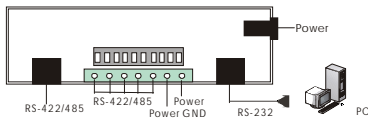

LED Indicators

There are LED indicators for Tx/D, Rx/D, RTS, CTS and PWR on top of A52/A53. The indicator is not lighted on when not connected with signal or power. On the contrary, it will be lighted on and be in the green color.

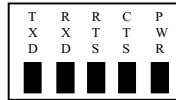

TxD: It shows green when connected and transmitting data from RS-232 to RS-422/485.

RxD: It shows green when connected and receiving data from RS-232 to RS-422/485.

RTS: It shows green when connected and RS-232 RTS Signal is ON.

CTS: It shows green when connected and RS-232 CTS Signal is ON.

PWR: It shows green when power is ON.

Power supply

For use in industrial environment A52/53 converters are designed for standard +24Vdc unregulated power. Operation is guaranteed when using any power supply between +9 and +30 Vdc, 350mA.

Optional power adapter (9V 1.5A UL/TUV 110V/230V) can support up to 4 converters. (See the following diagram)

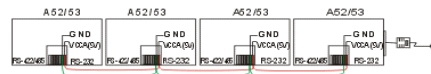

A52/53 Converter Connection Diagram

RS-232 Pinouts

RS-232 interface with RJ-45 connector is depicted as follows.

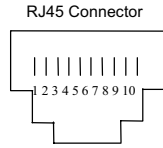

A52/A53 RJ45 Connector Pinouts	RS-232 Signals
1	DCD Always On
2	DTR
3	CTS
4	GND
5	RxD
6	TxD
7	GND
8	RTS
9	DSR
10	-

Note: Each group of (DTR, DSR) pins have been shorted on A52/A53, which release the users from the hardware flow control cable wiring problem. Thus, there are two types of RS-232 cable wiring which are listed below.

Type 1: To connect RS-232 side of A52/A53 to a DTE (e.g. PC COM1/2) or DCE. (Please check the precise DTE/DCE pinouts, the following DTE/DCE pinouts is just an example)

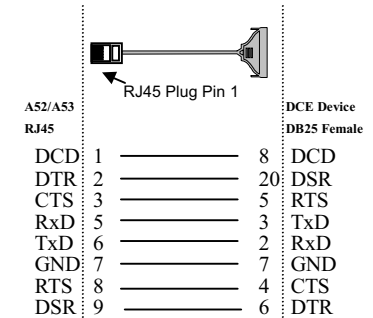
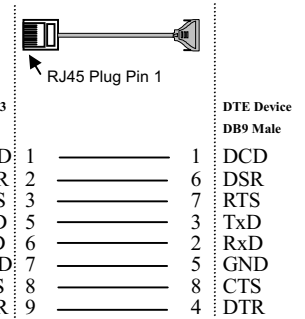
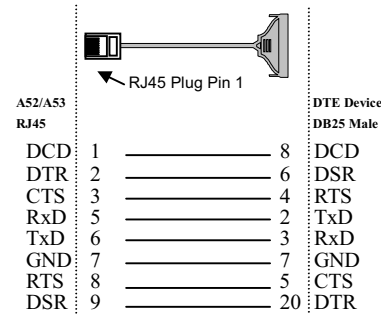

Type 2: To connect RS-232 side of A52/A53 to a DTE, e.g. terminal or PC COM1/2, with 3-pin wiring if don't care Hardware flow control.

