

JZC-43F (HF43F) SUBMINIATURE INTERMEDIATE POWER RELAY



File No.: E133481



File No.: 40002220



File No.:CQC02001001935



Features

- Extremely small footprint utilizing PCB area
- 10KV impulse withstand voltage (between coil and contacts)
- Highly efficient magnetic circuit for high sensitivity (200 mW)
- Class F insulation
- Environmental protection product available (RoHs & WEEE compliant)

CONTACT DATA

Contact Arrangement	1A
Initial Contact Resistance Max.	100mΩ (at 1A/ 24VDC)
Contact Material	See ordering info.
Contact Rating (Res. Load)	3A 250VAC, 3A 30VDC
Max. switching voltage	277VAC, 30VDC
Max. switching current	5A
Max. switching power	831VA, 90W
Mechanical life	10 ⁷ OPS
Electrical life	1 x 10 ⁵ OPS (at 3A, 250VAC) 2 x 10 ⁵ OPS (at 3A 125VAC, 3A 30VDC) 5 x 10 ⁴ OPS (at 5A, 250VAC)

CHARACTERISTICS

Initial Insulation Resistance	1000MΩ 500VDC	
Dielectric Strength	Between coil and Contacts	4000VAC 1min
	Between open contacts	750VAC 1min
Surge Voltage between Contacts and coil	10KV (1.2X50μs)	
Operate time (at nomi. Volt.)	Max. 10ms	
Release time (at nomi. Volt.)	Max. 10ms	
Temperature rise (at nomi. Volt.)	45°C	
Shock Resistance	Functional	100 m/s ²
	Destructive	1000 m/s ²
Vibration Resistance	1.5mm, 10 to 55Hz	
Humidity	35% to 85%	
Ambient temperature	-40°C to +85°C	
Termination	PCB	
Unit weight	Approx. 4g	
Construction	Sealed IP67	

COIL

Coil power	200mW
Coil Voltage	4.5 to 24VDC
Coil Resistance	See table

COIL DATA

Nominal Voltage VDC	Pick-up Voltage VDC	Drop-out Voltage VDC	Max. allowable Voltage VDC(at 20°C)	Coil Resistance Ω
4.5	3.38	0.23	5.85	101 ± 10%
5	3.75	0.25	6.50	125 ± 10%
6	4.50	0.30	7.80	180 ± 10%
9	6.75	0.45	11.7	405 ± 10%
12	9.00	0.60	15.6	720 ± 10%
18	13.5	0.90	23.4	1620 ± 10%
24	18.0	1.20	31.2	2880 ± 10%

SAFETY APPROVAL RATINGS

UL	3A 250VAC
	3A 30VDC
	3A 125VAC
VDE	3A 250VAC
	5A 250VAC



HONGFA RELAY

ISO9001、ISO/TS16949、ISO14001、OHSAS18001 CERTIFIED

VERSION: EN03-20050301

ORDERING INFORMATION

Type		JZC-43F / 012 H S T G XXX
Coil voltage	4.5, 5, 6, 9, 12, 18, 24VDC	
Contact arrangement	1H:1 Form A	
Structure	S: Sealed IP67	
Contact material	2: AgCdO T: AgSnO ₂ Nil: AgNi	
Contact material	G: Au plated Nil: No Au plated	
Special request code	(For example: 551: Lead-free 555: RoHs & WEEE compliant)	

OUTLINE DIMENSIONS, WIRING DIAGRAM AND PC BOARD LAYOUT

Outline Dimensions

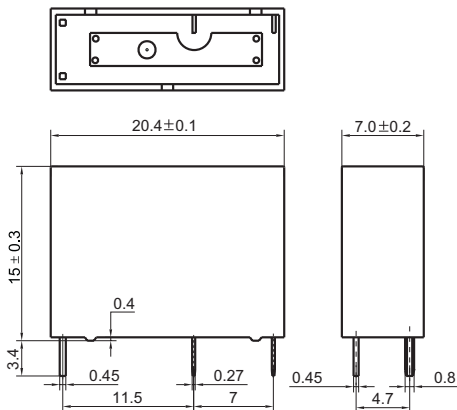

PCB Layout (Tolerance ± 0.1 mm)

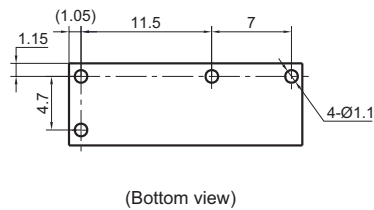

Wiring Diagram

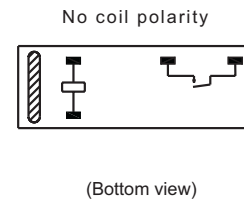

CHARACTERISTICS CURVE

COIL TEMPERATURE RISE

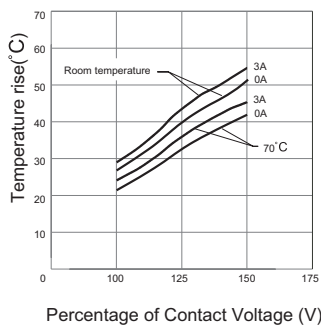

MAXIMUM SWITCHING POWER

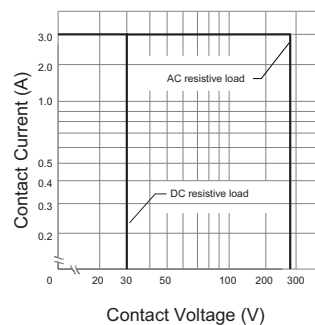

LIFE CURVE

