

RA30 Series

TOCOS[®]
PANEL CONTROLS

30mm Diameter, Single-Turn, Wirewound Industrial Panel Controls



Features

- 30mm diameter, single-turn industrial panel controls
- Wirewound element
- Linear or audio tapers
- Single, tandem and triple units, single shaft; dual unit, dual shaft
- SPST or SPDT switch with 1A or 3A rating
- Shaft lock and center tap models
- Metal shaft and bushing
- Temperature range of -10°C or -30°C , up to $+100^{\circ}\text{C}$
- Panel mount only
- 6mm diameter shafts in slot, flat or round end styles
- Standard 15mm or 20mm shaft length

Specifications

Electrical

Standard Resistance Range B = 5Ω to $20\text{k}\Omega$
A,C = 100Ω to $5\text{k}\Omega$

Resistance Tolerance $\pm 10\%$ standard
($\pm 5\%$, $\pm 2\%$ or $\pm 1\%$ special order)

End Resistance $R < 500\Omega = 1\Omega$ max.
 $R \geq 500\Omega = 0.2\%$ max.

Resistance Taper B = linear; A = CW audio (logarithm);
C = CCW audio (logarithm)

Power Rating B = 2.5 watts; A,C = 1.25 watts, at $+40^{\circ}\text{C}$

Insulation Resistance $100\text{M}\Omega$ minimum at 500VDC

Dielectric Strength 500VAC, 1 minute

Theoretical Resolution

Resistance (Ω)	Resolution (%)	Resistance (Ω)	Resolution (%)
5	1.62	500	0.23
10	0.81	1,000	0.19
20	0.67	2,000	0.15
50	0.45	5,000	0.14
100	0.44	10,000	0.12
200	0.32	20,000	0.10

Mechanical

Mechanical Travel $300^{\circ} \pm 5^{\circ}$

Shaft Torque

- Single Unit 70.1 to 306 gf·cm (0.972 to 4.242 oz·in)
- Tandem Unit 70 to 701 gf·cm (0.97 to 9.718 oz·in)
- Other Units 70 to 450 gf·cm (0.97 to 6.238 oz·in)

Stop Strength 10.2 kgf·cm (141.4 oz·in) max.

Mounting Nut Torque 15 kgf·cm (207.94 oz·in) max.

Solderability 235°C , 3 seconds

Marking Taper, resistance, resistance tolerance, terminal identification, date code

Environmental

Temperature Range Y = -10°C to $+100^{\circ}\text{C}$
or X = -30°C to $+100^{\circ}\text{C}$

Temperature Characteristics $+85^{\circ}\text{C}$, 5 hours
without load
 $\Delta T/R \leq \pm 5\%$

Low Temperature Exposure -10°C (Y), -30°C (X)
1 hour without load
 $\Delta T/R \leq \pm 3\%$

Load Life $+40^{\circ}\text{C}$, 1,000 hours with rated load
 $\Delta T/R \leq \pm 3\%$

Moisture and Load Life $+40^{\circ}\text{C}$, 90-95% RH,
500 hours with 1/10 rated load
 $\Delta T/R \leq \pm 5\%$

Vibration 10-55Hz, 1.5mm amplitude,
2 directions, 2 hours each
 $\Delta T/R \leq \pm 1\%$

Soldering Heat Resistance 350°C , 3.5 seconds;
 $\Delta T/R \leq \pm 2\%$

Rotational Life 15,000 cycles (500 cycles for shaft lock
models only) with 1/2 rated load
 $\Delta T/R \leq \pm 3\%$

Standard Rotary Switches

Switch Rating 110VAC, 1A or 3A, SPDT or SPST

Contact Resistance 0.05Ω max.

Operating Torque 1,500 gf·cm (20.79 oz·in) max.

Operating Life 10,000 cycles without load

R = Total Resistance Value; $\Delta T/R$ = Total Resistance Change

TOCOSAMERICA, INC.

1177 East Tower Road, Schaumburg, IL 60173 Tel: 847-884-6664 Fax: 847-884-6665 E-mail: sales@tocos.com www.tocos.com

RA30Y & RA30X
Panel Mount, Single Unit, Single Shaft
Right Angle Ear-Lug Terminals

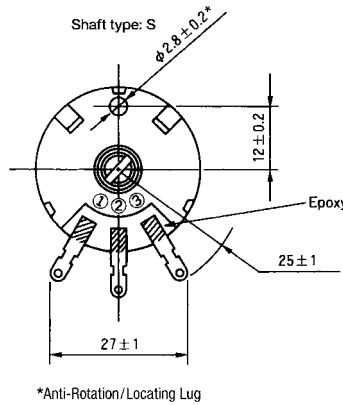
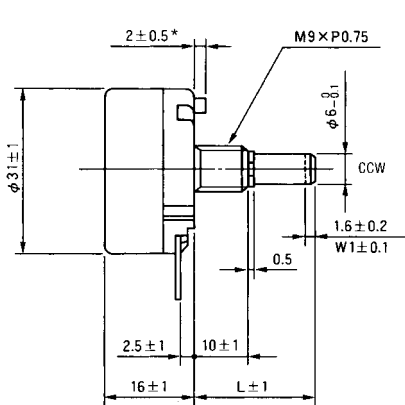

Recommended Panel Mounting Holes

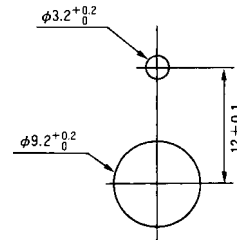

RA30YL & RA30XL
Panel Mount, Single Unit, Single Shaft with Shaft Lock
Right Angle Ear-Lug Terminals

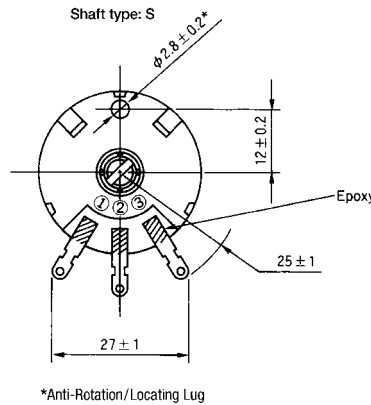
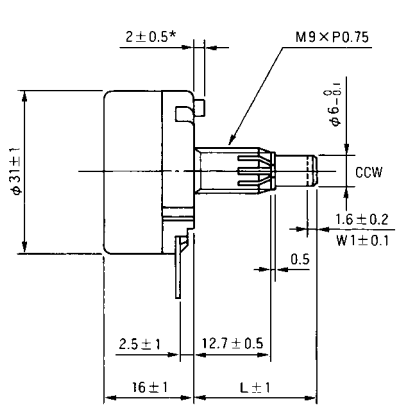

Recommended Panel Mounting Holes

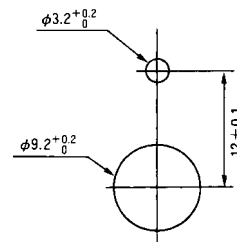

RA30YME, RA30YMF, RA30YSE, RA30YSF
RA30XME, RA30XMF, RA30XSE, RA30XSF
Panel Mount, Single Unit with Switch, Single Shaft
Right Angle Ear-Lug Terminals, Rear Exit Lug Terminals for 1A or 3A SPST or SPDT Switch

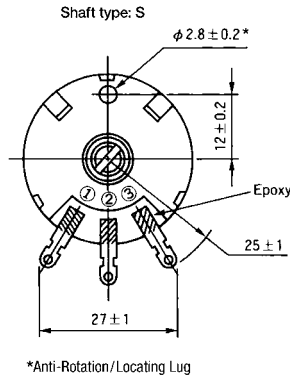
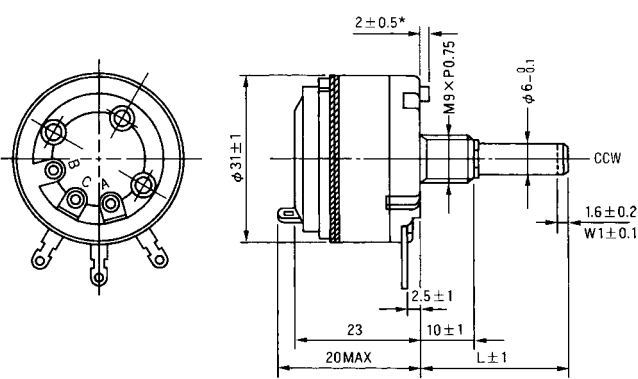

Recommended Panel Mounting Holes

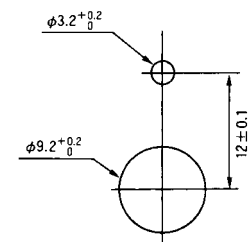

RAT30Y
Panel Mount, Single Unit with Center Tap, Single Shaft
Right Angle Ear-Lug Terminals, Tap Lug Terminal 105° from Terminal #1

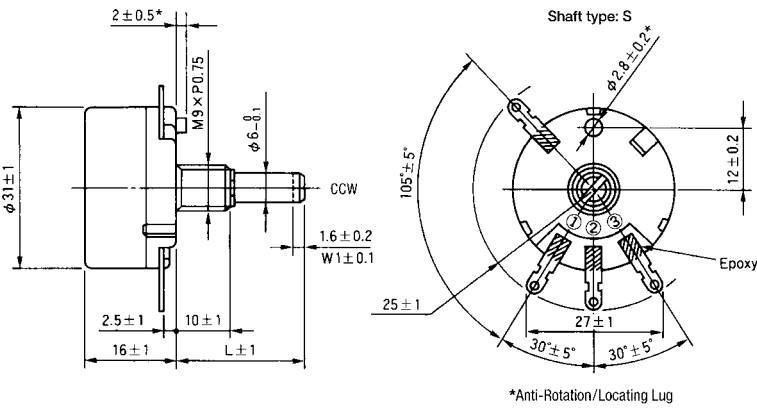

Recommended Panel Mounting Holes

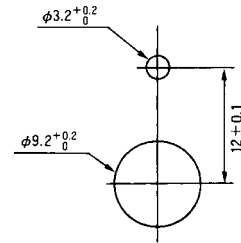

RA30YG
Panel Mount, Ganged Tandem Unit, Single Shaft
Right Angle Ear-Lug Terminals on Each Unit

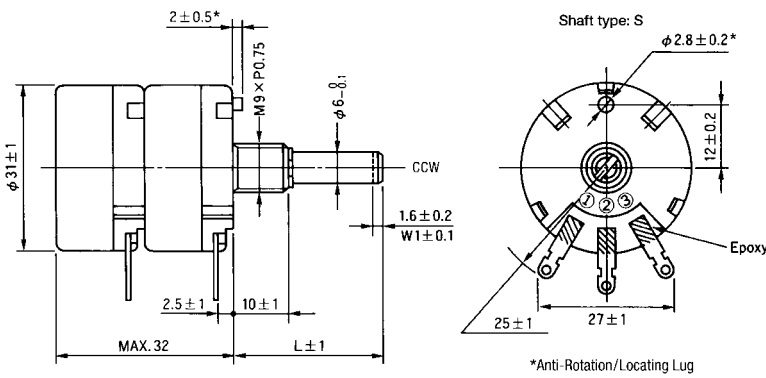

Recommended Panel Mounting Holes

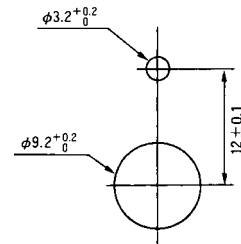

RA30YGL
Panel Mount, Ganged Tandem Unit, Single Shaft with Shaft Lock
Right Angle Ear-Lug Terminals on Each Unit

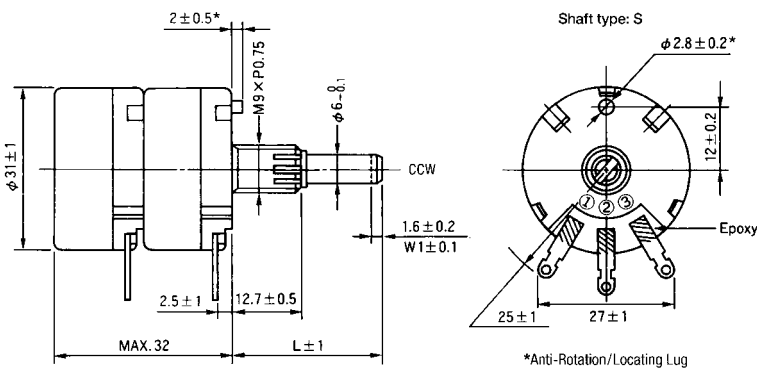

Recommended Panel Mounting Holes

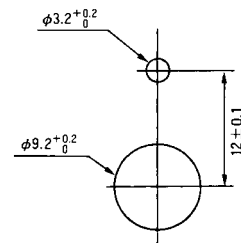

RAT30YG
Panel Mount, Ganged Tandem Unit with Center Tap, Single Shaft
Right Angle Ear-Lug Terminals, Tap Lug Terminal 105° from Terminal #1

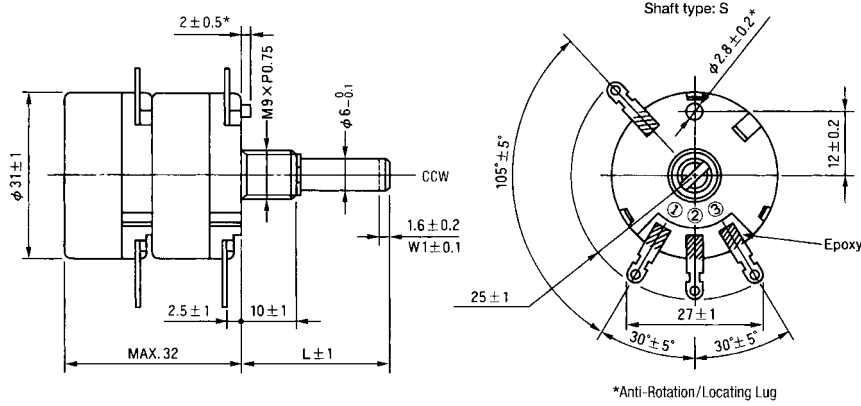

Recommended Panel Mounting Holes

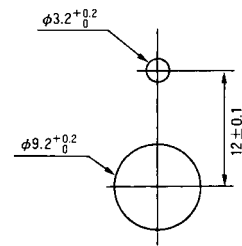

RA30YT
Panel Mount, Triple Unit, Single Shaft
Right Angle Ear-Lug Terminals on Each Unit

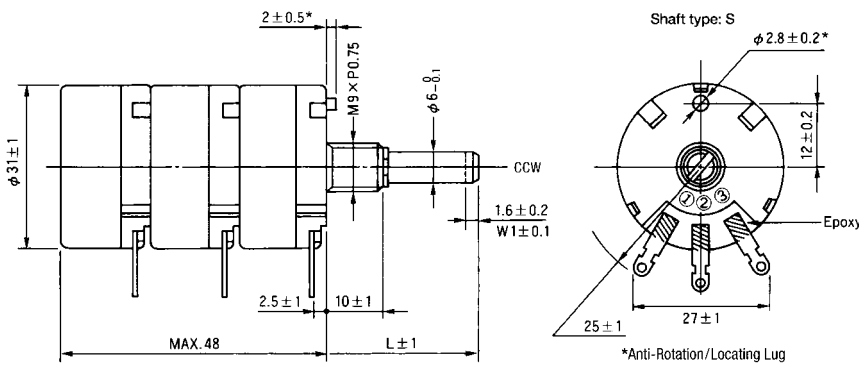

Recommended Panel Mounting Holes

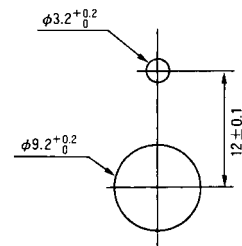

RA30YD
Panel Mount, Dual Unit, Dual Concentric Shaft
Right Angle Ear-Lug Terminals on Each Unit

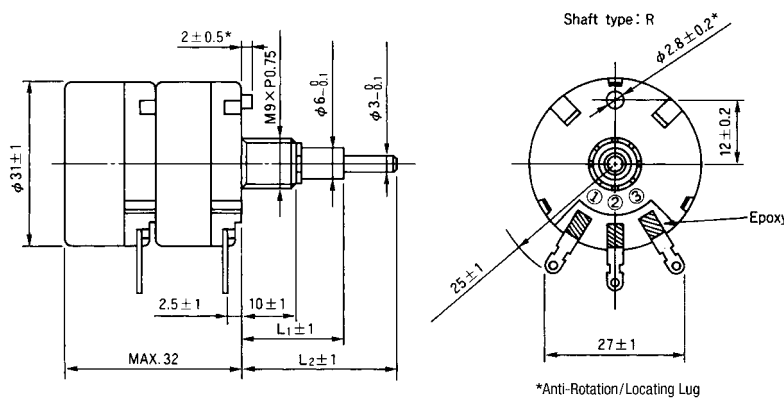

Recommended Panel Mounting Holes

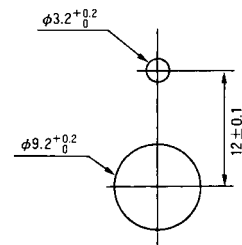

RA T 30 Y L ME 20 S B 102 K

NOTE: FMS = From Mounting Surface

- **Resistance Tolerance: K** = ±10% (standard).
J = ±5%; **G** = ±2%; or **F** = ±1% (special order).
- **Resistance Code:** Expressed in ohms. A three digit code where the first two digits are significant figures, and the third digit indicates the number of zeros that follow these figures. R indicates decimal point for resistance less than 10Ω (i.e., 5R0 = 5Ω; 100 = 10Ω; 101 = 100Ω; 102 = 1,000Ω; 103 = 10,000Ω). See table for standard resistance values.
- **For Single Unit:** Specify taper and resistance code as shown.
- **For Ganged Tandem Unit or Dual Unit:**
 Specify a taper code and resistance code for each unit starting with the front unit followed by the rear unit. If both units have the same taper and resistance codes, add "X2" suffix per example below.
 Examples: **B102A503** or if both units are the same: **B102X2**
- **For Triple Unit:**
 Specify a taper code and resistance code for each unit starting with the front unit followed by the middle and rear units. If all units have the same taper and resistance codes, add "X3" suffix per example below.
 Examples: **B102A503B104** or if all units are the same: **B102X3**
- **Resistance Taper: B** = Linear; **A** = CW Audio (logarithm);
C = CCW Audio (logarithm).
- **Shaft End Style: S** = Slotted; **F** = Flatted; **R** = Round.
- **For Single Shaft:**
 Specify the shaft length (FMS) and shaft end style as shown.
- **For Dual Concentric Shaft:**
 Specify the shaft length (FMS) and shaft end style for the inner shaft followed by the shaft length (FMS) and shaft end style for the outer shaft. Use a dash (-) to separate the code groups for the inner and outer shaft specifications. Example: **30R-20R**
- **Standard Shaft Length: 15** = 15mm FMS; **20** = 20mm FMS.
 Up to 50mm shaft length available (special order).
- **Switch Type: ME** = SPDT, 110VAC, 1A, Rear Exit Lug Terminals.
MF = SPDT, 110VAC, 3A, Rear Exit Lug Terminals.
SE = SPST, 110VAC, 1A, Rear Exit Lug Terminals.
SF = SPST, 110VAC, 3A, Rear Exit Lug Terminals.
Blank = No Switch.
- **Style: Blank** = Panel Mount, Single Unit, Single Shaft, Right Angle Ear-Lug Terminals.
L = Panel Mount, Single Unit, Single Shaft with Shaft Lock, Right Angle Ear-Lug Terminals.
G = Panel Mount, Ganged Tandem Unit, Single Shaft, Right Angle Ear-Lug Terminals on Each Unit.
GL = Panel Mount, Ganged Tandem Unit, Single Shaft with Shaft Lock, Right Angle Ear-Lug Terminals on Each Unit.
T = Panel Mount, Triple Unit, Single Shaft, Right Angle Ear-Lug Terminals on Each Unit.
D = Panel Mount, Dual Unit, Dual Concentric Shaft, Right Angle Ear-Lug Terminals on Each Unit.
- **Operating Temperature Range: Y** = -10°C to +100°C.
X = -30°C to +100°C.
- **Size: 30** = 30mm Diameter.
- **Center Tap: T** = With Tap; **Blank** = Without Tap.
- **TOCOS Series Name: RA** = Wirewound Element.

Standard Resistance Values and Part Numbering Codes

Standard Nominal Total Resistance Values and Part Numbering Codes

Resistance (Ω)	Code	Resistance (Ω)	Code	Resistance (Ω)	Code	Resistance (Ω)	Code
5	5R0	100	101	1,000	102	10,000	103
10	100	200	201	2,000	202	20,000	203
20	200	500	501	5,000	502		
50	500						

Refer to Shaft End Styles Specifications and Hardware Specifications for details and availability. For additional information, refer to Guidelines and Precautions for Using Panel Controls.